

# 2011 ICE DOORS

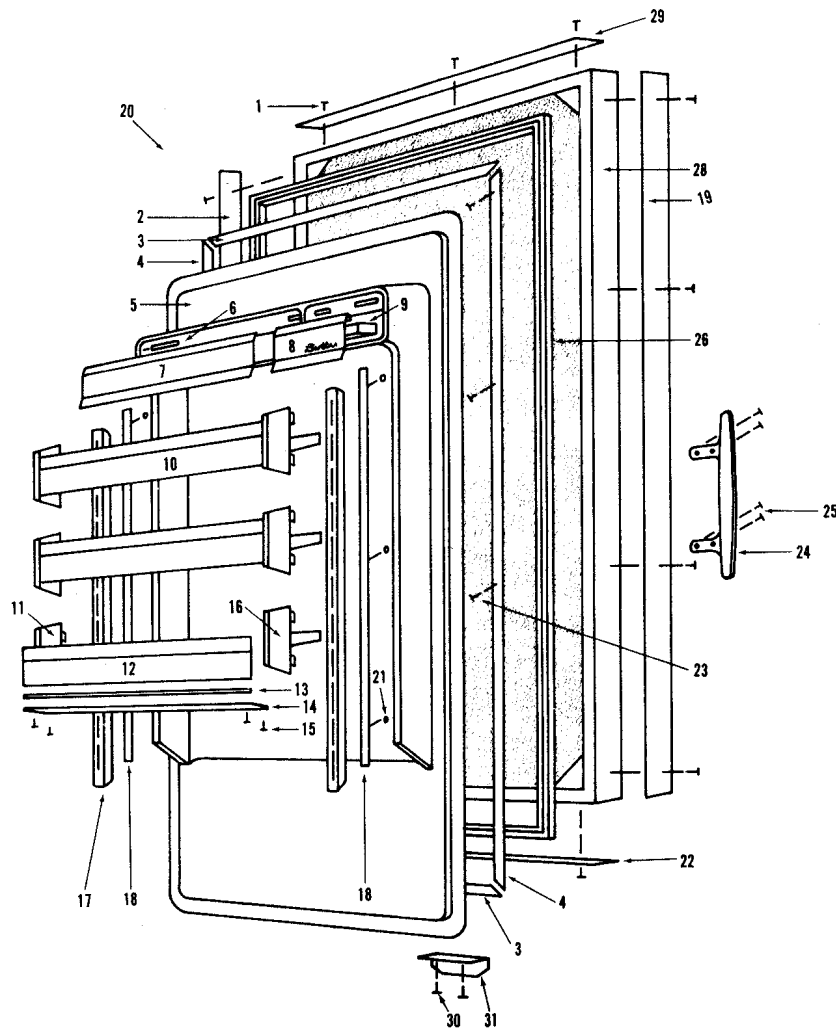

Item #	Part #	Description	Item #	Part #	Description
1	6-20-004-0	Screw, #4-24 x 1/2 Truss Head	17	2-2145-08	Door Shelf Ladder, 33-1/8
2	2-2191-01	Side Door Trim, 2.07 x 59-1/8	18	4-15-019-0	Door Shelf Ladder Holder Assembly, 29.5
3	3-42-022-0	Top & Bottom Gasket Retainer, 33.312	20	4-13-043-1	Complete Door Assembly, Right Hand
4	3-42-025-0	Side Gasket Retainer, 57.875		4-13-043-2	Complete Door Assembly, Left Hand
5	0-18211-0	Refrigerator Door Liner	21	6-15-032-0	Nut, #8-32 Pal (D0832075)
6	3-42-005-0	Butter Door Rod, 3/16 x 2	22	2-2182-02	Bottom Door Trim, Right Hand
7	3-48-035-0	Dairy Door, 4.875 x 20.25		2-2182-01	Bottom Door Trim, Left Hand
8	3-48-036-0	Butter Door, 4.875 x 7.688	23	6-20-041-0	Screw, #8 x 1/2 Slot Head Hex
9	3-44-001-0	Butter Dish, 3-1/8 x 6-1/8	24	3-51-001-0	Door Handle; Cast, 13-1/2
10	4-33-011-0	Door Shelf Assembly	25	6-11-001-0	Boit, #10-24 x 1/2 Flat Head
11	3-60-022-2	Left Side Door Shelf End Cap	26	3-21-005-0	Door Gasket, 33.813 x 58.375
12	3-51-011-0	Door Shelf Guard, 28.375	28	0-17047-0	Door Shell
13	1-2163-00	Door Shelf Support, 25-7/8	29	2-2182-01	Top Door Trim; Right Hand, 2.07 x 34-5/16
14	2-8061-01	Door Shelf Tray, 26.81		2-2182-02	Top Door Trim; Left Hand, 2.07 x 34-5/16
15	6-20-039-0	Screw, #6 x 3/8 PH T25 Flat Head	30	6-20-023-0	Screw, #8-18 x 1/2 Hex Head
16	3-60-022-1	Right Side Door Shelf End Cap	31	0-18029-0	Switch Depressor, S/S

## 2011 ICE SYSTEM VIEW

Item #	Part #	Description	Item #	Part #	Description
1	4-20-017-0	Refrigerator Fan Motor, 23 Watt	48	4-28-042-0	Condenser Fan Shroud Assembly
2	3-01-246-0	Refrigerator Control	49	6-20-043-0	Screw, #8-18 x 1/2 PH Type B Pan Head
3	6-11-005-0	Bolt, #8-32 x 3/8 Truss Head	50	3-45-029-0	Angle Bracket, #8A
4	3-01-232-0	Control Knob	51	3-11-100-0	Terminal Cover
5	3-15-021-0	Fan Blade, 4"	52	3-11-101-0	Terminal Cover Strap
6	0-21137-0	Control Shim	53	3-15-001-0	Rubber Mount, 5/8 x 1-1/4
7	3-13-013-0	Refrigerator Evaporator, 1.5 x 10 x 29.6	54	3-45-004-0	Compressor Clip, 7/8 x 3/16
8	6-20-012-0	Screw, #10-12 x 1/2 PH Truss Head	55	3-09-008-0	Valve Cap
9	6-20-014-0	Screw, #8-15 x 3/8 PH Truss Head	56	3-09-001-0	Base Valve
10	0-23258-0	Freezer Fan Deflector	57	3-11-079-0	Overload (MM3-30K)
11	6-11-032-0	Bolt, #10-32 x 7/8 PH Truss Head	58	3-11-078-0	Start Relay (MM5-46S)
12	0-21129-0	Refrigerator Fan Bracket	59	3-11-077-0	Compressor (FN43-F67R)
13	6-15-033-0	Wellnut, #10-32	60	3-02-229-0	Power Cord, Gray
14	6-20-009-0	Screw, #8-15 x 1-3/4 PH Truss Head	61	6-24-002-0	Star Washer, 3/16
15	6-20-008-0	Screw, #8-15 x 1/2 PH Truss Head	62	6-20-015-0	Screw, #10 x 3/4 T23 PH Round Head
16	3-01-247-0	Freezer Control	63	3-52-023-0	Compression Nut
17	0-23244-0	Freezer Evaporator Cover	64	3-52-022-0	Ball Sleeve
18	4-19-010-0	Freezer Drain Trough Assembly	65	3-52-021-0	Water Valve Fitting
19	4-20-030-0	Icemaker (With Item 20)	66	3-21-003-0	Water Valve Gasket
20	3-42-102-0	Icemaker Roller Half (2 Required)	67	3-52-003-0	Icemaker Nylon Nut, 1/4
21	3-55-032-0	Hole Plug, 1/2	68	3-52-005-0	Brass Insert, Solenoid
22	2-6008-05	Water Inlet Tube	69	3-09-002-0	Solenoid Valve
23	2-6006-11	Plastic Water Tube, 53	70	3-52-011-0	Water Inlet Fitting Assembly
24	3-15-007-0	Condenser Fan Motor; 4 Pole, 1.5 Watt	71	3-06-003-0	Door Switch, Normally Closed (Light)
25	3-21-034-0	Neoprene Silencer, 7/8"	72	3-06-002-0	Door Switch, Normally Open (Fan)
26	6-15-041-0	Nut, 1/4-20	73	3-01-405-0	Drier, 1/4 x .095
27	3-15-032-0	Fan Blade; Plastic, 5 Prop, 7"	74	4-25-084-0	Refrigerator Heat Exchanger Assembly
28	6-20-049-0	Screw, #8-32 x 3/8 T25 Slotted Hex	75	4-19-011-0	Refrigerator Drain Trough, Right Assembly
29	6-22-029-0	Standoff, #5-32 x 5/16	76	4-25-083-0	Freezer Heat Exchanger Assembly
30	3-22-016-0	Grommet, 3/16 x 7/16 x 9/32	77	4-32-181-0	Defrost Heater
31	6-20-061-0	Screw, #6-32 x 3/8 PH Round Head Zinc	78	3-01-332-0	Drain Tube Heater, 28-1/2
32	2-8016-03	Condenser Fan Bracket, 1-7/8	79	3-01-106-0	Accumulator
33	6-20-034-0	Screw, #6-20 x 1/2 Pan Head	80	4-32-177-0	Defrost Terminator Assembly
34	3-08-105-0	Defrost Timer	81	3-13-016-0	Freezer Evaporator, 2-1/4 x 5 x 9
35	6-20-006-0	Screw, #8-32 x 1/2 Pan Head	82	0-23245-0	Freezer Evaporator Mounting Plate
36	3-12-018-1	Condenser, 1-1/2 x 8 x 13-3/4	83	2-4015-02	Insulator Plate
37	6-11-002-0	Bolt, #10-24 x 3/8 Truss Head	84	3-21-059-0	Sleeve Rear Gasket
38	6-15-008-0	Nut, #10-24 Flat	85	4-19-009-0	Refrigerator Left Drain Trough Assembly
39	1-6014-00	Drain Tube, 1/2" x 72"	86	0-16509-0	Cold Plate Spacer
40	6-12-005-0	Tube Clamp, 5/8	87	6-11-027-0	Bolt, #10-32 x 1/4 Round Head
41	6-20-001-0	Screw, #10-12 x 3/4 Pan Head	88	0-21099-0	Refrigerator Fan Shroud
42	0-16494-0	Drain Pan, 1.3 x 13.5 x 19.5	89	3-05-003-0	Light Socket
43	2-6041-01	Condensate Heater Loop	90	3-03-003-0	Light Bulb, 40 Watt
44	6-22-021-0	Standoff, Heater Clip	91	0-16488-0	Solenoid Bracket
45	3-42-076-0	Drain Pan Holder	92	0-16511-0	Switch Housing
46	3-42-067-0	Screw Spacer	93	6-20-002-0	Screw, #7-16 x 1/2 Pan Head
47	6-20-044-0	Screw, #10-12 x 11/16 Type B Flat Head			

# 2011 ICE SYSTEM VIEW

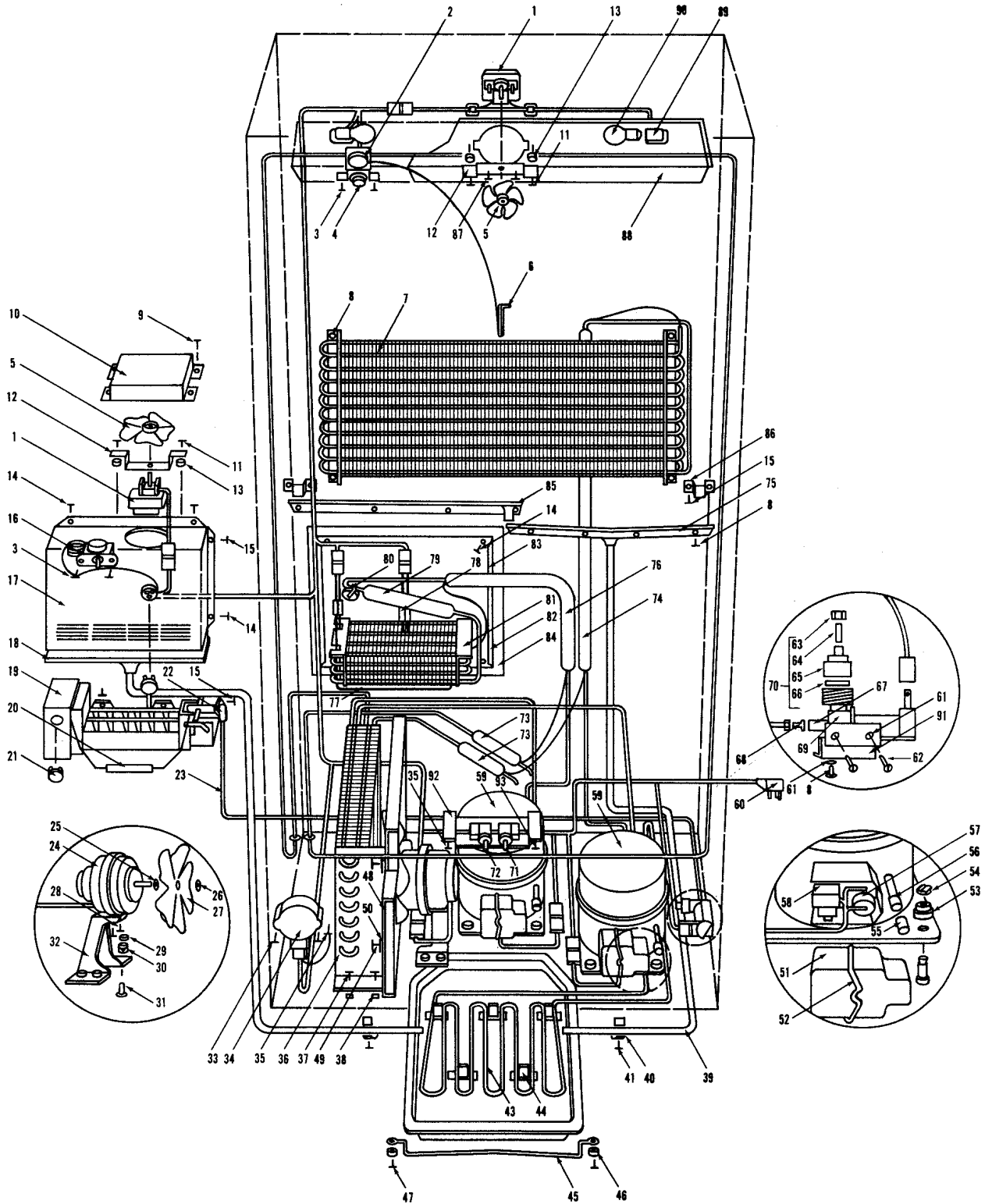

# 2011 ICE COSMETIC VIEW

Item #	Part #	Description	Item #	Part #	Description
1	6-20-021-0	Screw, #8-32 x 1/2 Flat Head	50	3-21-060-0	Front Crisper Seal, 15-15/32
2	2-2195-08	Left Side Main Frame Extrusion, Right Hand	51	3-21-025-0	Rear Crisper Seal, 3/8 x 3/8
	2-2195-26	Left Side Main Frame Extrusion, Left Hand	52	4-15-083-0	Crisper Tray Assembly
4	6-20-023-0	Screw, #8-18 x 1/2 Hex Head	53	3-48-068-0	Crisper Front Only (Veg.), 14.647
5	0-16504-0	Back Cover, White		4-18-050-0	Crisper Basket Assembly (Veg.), 15.00 x 15.95
6	4-11-002-2	Left Base Assembly	54	3-41-028-0	Crisper Basket Only, 15.00 x 5.68 x 15.96
7	3-57-004-0	Leveling Leg, 3/8-18 x 1-1/2	55	3-48-073-0	Crisper Handle, .44 x 14.49 x 1.53
8	6-20-001-0	Screw, #10-12 x 3/4 Pan Head	56	3-42-032-0	Roller, .250 x .75
9	6-22-004-0	Rubber Bumper, 1/2"	57	6-20-044-0	Screw, #10 x 11/16 Type B Flat Head
10	6-20-002-0	Screw, #7-16 x 1/2 Pan Head	58	4-15-084-0	Crisper Glass Assembly
13	4-11-027-0	Unit Base Assembly	59	4-15-037-0	Crisper Trim Assembly, 31-5/8
14	6-11-002-0	Bolt, #10-24 x 3/8 Truss Head	60	3-60-030-0	Refrigerator Cantilever Shelf, 31"
15	4-11-002-1	Right Base Assembly	61	3-41-015-0	Plastic Egg Tray
16	6-11-001-0	Bolt #10-24 x 1/2 Flat Head UC	62	3-45-016-0	U-Clip, .248 x .354 x .50
17	4-15-076-1	Bottom Cabinet Hinge, Right Hand	63	4-15-031-0	Diffuser Glass Assembly, 5.25 x 31.563
	4-15-076-2	Bottom Cabinet Hinge, Left Hand	64	4-15-077-1	Top Door Hinge, Right Hand
18	6-11-027-0	Bolt, #10-32 x 1/4 Round Head		4-15-077-2	Top Door Hinge, Left Hand
19	3-42-068-1	Bottom Cabinet Hinge Cam, Right Hand	65	6-20-007-0	Screw, #4-24 x 3/8 Flat Head
	3-42-068-2	Bottom Cabinet Hinge Cam, Left Hand	66	0-18256-0	Top Cabinet Hinge
20	3-42-069-0	Bottom Door Hinge Cam, Right or Left Hand	67	6-11-007-0	Bolt, 1/4-20 x 5/8 Hex Head
21	0-18238-1	Bottom Door Hinge, Right Hand	68	2-2195-25	Right Side Main Frame Extrusion, Right Hand Door
	0-18238-2	Bottom Door Hinge, Left Hand		2-2195-02	Right Side Main Frame Extrusion, Left Hand Door
22	0-16477-0	Kickplate, 3-7/16 x 35-1/2	69	2-2107-01	Main Frame Angle, 1.5 x .25
23	6-20-005-0	Screw, #10-12 x 1/2 Pan Head	70	2-2195-15	Top Main Frame Extrusion, 36 (Right Hand Door)
24	6-15-014-0	Spring Clip Nut, 1/3		2-2195-16	Top Main Frame Extrusion, 36 (Left Hand Door)
25	3-58-010-0	Sub Zero Name Plate	71	6-22-019-0	Plastic Support, .275 x .750
26	4-24-001-0	Grille Assembly	72	6-22-007-0	Support, .44 x .63 x 1.53
27	6-20-008-0	Screw, #8-15 x 1/2 Truss Head	73	6-20-013-0	Screw, #8-15 x 3/4 PH Truss Head S/S
28	0-16474-0	Grille Cover, Right Hand	74	6-20-014-0	Screw, #8-15 x 3/8 Truss Head
	0-16475-0	Grille Cover, Left Hand	75	2-2216-06	Left Refrigerator Shelf Ladder
29	4-20-038-0	Ice Compartment Kit Assembly		2-2216-05	Right Refrigerator Shelf Ladder
30	4-20-039-0	Ice Door Handle Kit Assembly	77	6-12-020-0	Cable Clip, .22 x .79 x .50
31	4-20-044-0	Ice Compartment Door Assembly	78	0-20061-0	Refrigerator Cold Plate Cover
32	6-18-004-0	Pop Rivet, 3/16 x 1/8 Grip	80	3-55-016-0	Hex Insert, #10-32 x 3/8
33	6-20-012-0	Screw, #10-12 x 1/2 Truss Head	81	6-20-058-0	Screw, #10-32 x 3/16 PH Truss Head
34	6-24-001-0	Finish Washer, #10 S/S	82	6-11-033-0	Screw, #10-32 x 1/2 Flat Head Chrome
35	6-20-054-0	Adjusting Screw, 1/4-20	83	4-18-072-0	Center Crisper Slide Assembly
36	4-33-023-0	Sleeve Assembly	84	6-22-020-0	Support; Barrel Type, .225 x .406
37	0-23251-0	Ice Compartment Baffle	85	3-42-030-0	Center Crisper Support, .29 x .31 x 6.25
39	6-11-041-0	Bolt, 1/4-20 x 1 PH Truss Head S/S	86	2-8073-13	Right & Left Side Breaker Strip, 57-1/8
40	0-23243-0	Spring Support Plate	87	6-20-045-0	Screw, #8-15 x 1 Type AB Flat Head
41	3-45-034-0	Extension Spring, 1/2 x 5 x .063	88	4-18-062-1	Right Crisper Slide Assembly
42	3-43-002-0	Nylon Shoulder Washer	89	4-18-062-5	Right Crisper Slide Assembly
43	3-42-007-0	Hinge Bearing, 1/4 x 5/8	90	2-8073-15	Top & Bottom Breaker Strip, 32-7/8
44	3-60-068-0	Basket Support Tray	91	2-8087-01	Crisper Glass Support, 14-5/16
45	3-60-067-0	Ice Bucket Basket	92	3-41-077-0	Crisper Glass Cap
46	3-21-058-0	Ice Door Gasket, 13-9/16 x 11-1/16	93	6-18-013-0	Rivet, 3/16 x 1/2 Bulbex Aluminum
47	6-20-039-0	Screw, #6 x 3/8 PH Flat Head	94	6-20-057-0	Screw, #8 x 2-1/4 PH T25 Truss Head
48	0-16505-0	Ice Bucket	95	3-21-022-0	Front Crisper Seal, 30.44"
49	3-48-067-0	Crisper Front Only (Meat), 14.647	96	2-2203-01	Crisper Glass Front
	4-18-049-0	Crisper Basket Assembly (Meat), 15.00 x 15.95			

# 2011 ICE COSMETIC VIEW

